

# KDM-8206

## Non-Contact Displacement Measuring System

### Rack Reference Manual

1/2 Rack Instrumentation Case (3U/42HP)  
3/4 Rack Instrumentation Case (3U/63HP)  
Full 19" Sub-Rack (3U/84HP)

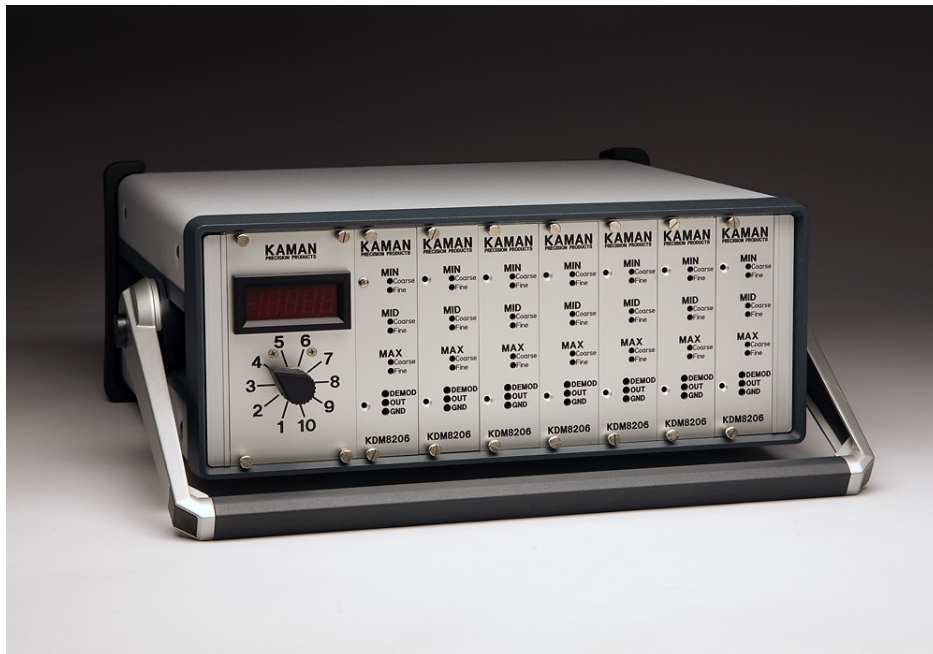

# Table of Contents

<b>PART 1 INTRODUCTION</b> .....	<b>4</b>
<b>PART 2 REAR PANEL CONNECTIONS</b> .....	<b>5</b>
<b>PART 3 MEASURING CHANNEL CONNECTIONS</b> .....	<b>6</b>
<b>3.1 Back Plane PCB</b> .....	<b>6</b>
<b>3.2 Back Panel PCB</b> .....	<b>8</b>
<b>PART 4 OPTIONAL DISPLAY MODULE</b> .....	<b>9</b>
<b>PART 5 ENCLOSURES</b> .....	<b>12</b>
<b>5.1 Full 19" Instrumentation Sub-Rack - 3U/84HP</b> .....	<b>12</b>
<b>5.2 1/2 Rack Instrumentation Enclosure - 3U/42HP</b> .....	<b>16</b>
<b>5.3 3/4 Rack Instrumentation Enclosure - 3U/63HP</b> .....	<b>21</b>
<b>PART 6 INTEGRAL POWER SUPPLY</b> .....	<b>25</b>
<b>6.1 Power Supply</b> .....	<b>25</b>
<b>6.2 Power Entry Module</b> .....	<b>26</b>
<b>APPENDIX A REPLACEMENT OR EXPANSION PARTS</b> .....	<b>27</b>

# List of Figures

Figure 1	Rear Panel I/O .....	5
Figure 2	Measuring Channel Back Plane PCB, Front View.....	6
Figure 3	Measuring Channel Back Plane PCB, Rear View .....	7
Figure 4	Back Panel PCB.....	8
Figure 5	Display Module Front Panel .....	9
Figure 6	Display Module Back Plane PCB, Front View .....	10
Figure 7	Display Module Back Plane PCB, Rear View.....	10
Figure 8	Back Panel P4 Jumper Configuration .....	11
Figure 9	Full 19" Sub-Rack Side Outline drawing .....	12
Figure 10	Full 19" Sub-Rack Rear / Front Outline drawing.....	13
Figure 11	Full 19" Sub-Rack Top View Outline Drawing .....	14
Figure 12	Full 19" Sub-Rack Front/Top with Display .....	15
Figure 13	1/2 Rack Front View Outline Drawing .....	17
Figure 14	1/2 Rack Rear View Outline Drawing .....	18
Figure 15	1/2 Rack Side/Top View Outline Drawing.....	19
Figure 16	1/2 Rack Top View With Display .....	20
Figure 17	3/4 Rack Front View Outline Drawing .....	21
Figure 18	3/4 Rack Rear View Outline Drawing .....	22
Figure 19	3/4 Rack Side/Top View Outline Drawing.....	23
Figure 20	3/4 Rack Top View With Display .....	24
Figure 21	Power Supply .....	26
Figure 22	Power Entry Module.....	26

## PART 1 - INTRODUCTION

The KDM-8206 is a modular packaging system for Kaman Precision Products' line of inductive displacement transducer electronics. The KDM-8206 enclosures integrate various measuring channels, power supplies, and displays into a coherent application specific industrial package. Sensors for the measuring channels are available that measure displacements in the micro inch/nanometer ranges as well as sensors that can make accurate displacement measurements at up to 1000°F. The KDM-8206 system is versatile and flexible. This manual is designed to help put it all together for the specific system you have purchased.

### *Features:*

- Inductive Sensing Technology
- Eurocard/Eurorack packaging
- Up to 12 Measuring Channels per rack system
- Integral power supply
- Single Ended or Differential Output Voltages
- 4-20mA outputs
- Optional Multi-channel display
- Optional Multi-rack synchronization

The KDM8206 rack systems are prewired and set up at the factory with all measuring channels installed. To get started with the 8206 system you will need to:

- Install the sensors in the application or cal fixture
- Connect the sensors to the enclosure (see the Back Panel Connections Section)
- Connect the power cord and turn on the unit
- If you have a display see the Optional Display Panel Section)

As with any complex electronics system you should thoroughly familiarize yourself with all the manuals dealing with the product. Refer to these manuals for specific information. Manuals are available on line @ [www.kamansensors.com](http://www.kamansensors.com)

**WARNING:** The integral rack power supply utilizes **high voltage** (120 or 240VAC). Unplug the unit before servicing.

## PART 2 - REAR PANEL CONNECTIONS

Refer to Figure 1 below. Twin BNC connectors on the bottom row are for connecting the Sensors to the rack or enclosure. The rack was configured at the factory to enable the measuring channel to use a single coil or dual coil sensor. If a measuring channel is being changed from a single coil sensor to a dual coil sensor, it will be necessary to add an additional RF cable between the measuring channel backplane board and backpanel board.

Measuring channel output voltages are available on two rows of (isolated from chassis) BNC connectors on the back panel.

- The upper row (V+) is for single ended outputs.
- The upper (V+) and lower (V-) are used for differential outputs. The lower (V-) connectors are present only if differential voltage output is specified at time of order.

Measuring channel output current (4-20 mA) is also available on the back panel through a terminal block. The plug in terminal block may be unplugged, connected to customer-supplied wire, and plugged back in.

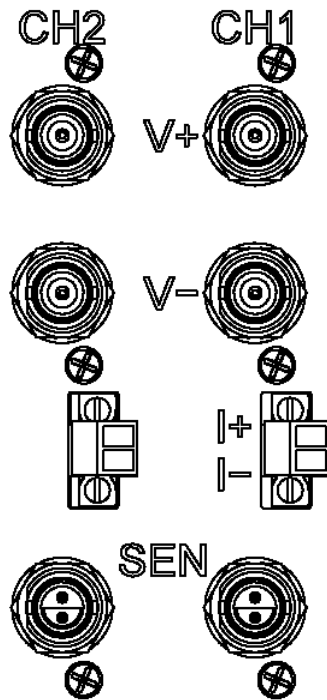

**Figure 1** Rear Panel I/O

## PART 3 - MEASURING CHANNEL CONNECTIONS

Internal wiring for each Measuring Channel in a rack or instrument enclosure is in modular format. Each Measuring Channel requires:

- A Back Plane PCB to connect to the Measuring Channel
- A Back Panel PCB for sensor input and analog voltage or current output
- A 6 inch interconnecting ribbon cable between back plane and back panel for output
- Interconnecting 6 inch coaxial cable(s) for sensor input. One cable is required for a single coil sensor. Two cables are required for a dual coil sensor.

### 3.1 Back Plane PCB

The Back Plane PCB is installed to the horizontal rails inside the rack and secured with four screws. A Back Plane PCB is required for each Measuring Channel installed in the rack. Its purpose is to provide all I/O connections to each Measuring Channel, which are:

- Sensor connections
- Input power
- Synchronization signal
- Analog output
- Optional Display Module input signals

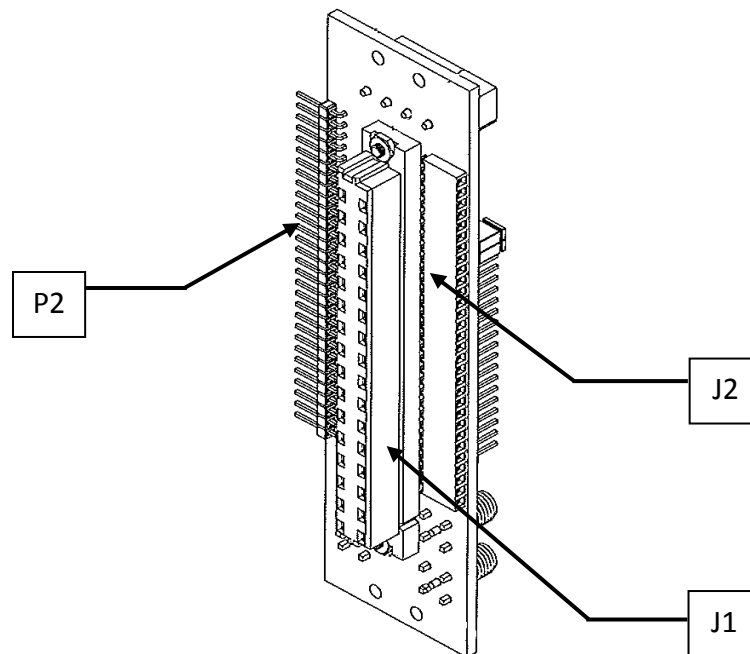

**Figure 2** Measuring Channel Back Plane PCB, Front View

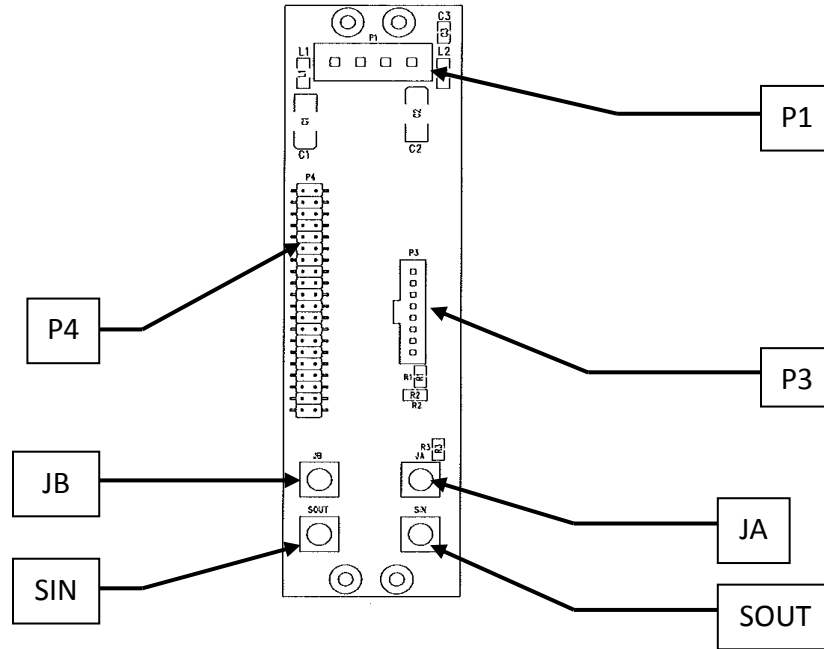

**Figure 3** Measuring Channel Back Plane PCB, Rear View

There are two versions of the Back Plane PCB. The Channel 1 version is installed in the channel 1 position only. The Channel 1 version is not installed if the rack has a display module, refer to Part 4 of this manual. The Channel 2+ version is installed for channel 2 and subsequent measuring channels in the rack. Differences between the two versions are the connectors installed. Connections to the Back Plane PCB are:

- **J1** Euro connector to Measuring Channel
- **J2** Connects to subsequent Measuring Channel Back Plane PCB.
- **JA** Sensor input for a single coil sensor. Sensor active coil for a dual coil sensor
- **JB** Sensor inactive coil for a dual coil sensor. Not connected for a single coil sensor
- **P1** Input DC power. Only present on channel 1 Back Plane PCB
- **P2** Connects to previous Measuring Channel Back Plane PCB. Only present on channel 2+ Back Plane PCB.
- **P3** Ribbon cable connector. To Back Panel PCB
- **P4** Dual row terminal strip for optional display module. Refer to Part 4 of this manual.
- **SIN** Synchronization signal input for optional multi-rack synchronization. Only present on channel 1 Back Plane PCB
- **SOUT** Synchronization signal output for optional multi-rack synchronization. Only present on channel 1 Back Plane PCB

## 3.2 Back Panel PCB

The Back Panel PCB is installed in the rack just as its name indicates, to the rear panel of the rack or instrument enclosure. It is secured to the rear panel with three flat head screws and with the BNC connector nuts. A Back Panel PCB is required for each Measuring Channel installed in the rack. Its purpose is to provide external I/O connections for each Measuring Channel and transmit them to the Back Plane PCB.

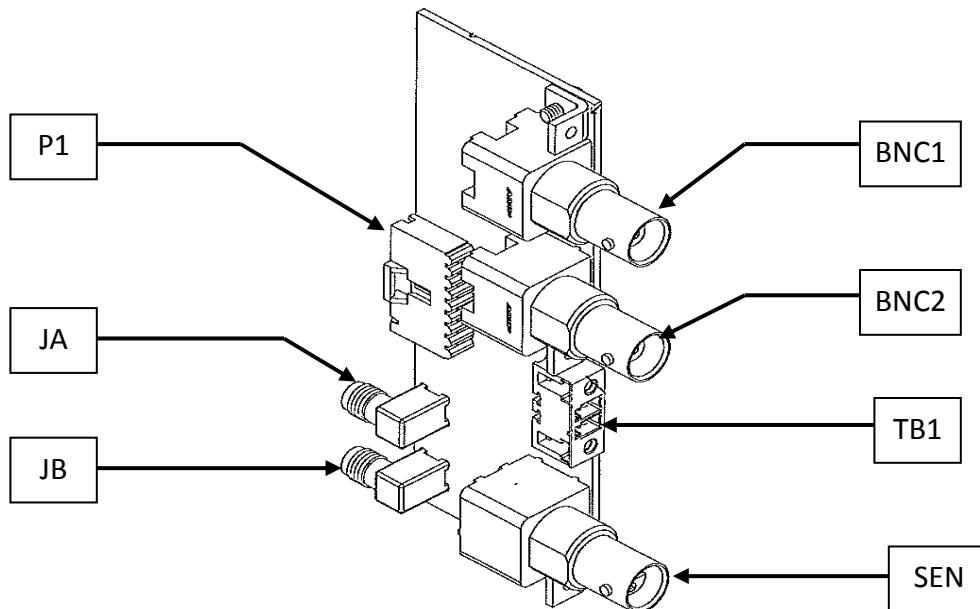

**Figure 4** Back Panel PCB

Connections to the Back Panel are:

- **BNC1** Coaxial V+ connector for single ended and differential voltage output.
- **BNC2** Coaxial V- connector for differential voltage output option. Not installed if this option is not requested.
- **JA** Sensor connection to Back Plane PCB for a single coil sensor. Sensor active coil for a dual coil sensor.
- **JB** Sensor inactive coil connection to Back Plane PCB for a dual coil sensor. Not connected for a single coil sensor.
- **P1** Ribbon cable connector to Back Plane PCB
- **SEN** Twin BNC sensor connector.
- **TB1** Two position terminal block for 4-20 mA current output.

## PART 4 – OPTIONAL DISPLAY MODULE

The Display Module provides a convenient method to monitor Measuring Channel output for Sub-Racks and Instrument Enclosures. The Display Module is a two slot wide panel with an LED display and selector switch. It can display output of a single Measuring Channel in the rack at a time. The Display Module must be installed in slots 1 and 2 of a rack or instrument enclosure.

The Display Module includes:

- a front panel with a 4-½ Digit  $\pm 10\text{VDC}$  LED display, a switchboard with a 10-position switch
- a back plane PCB for DC power and Measuring Channel input
- A ribbon cable connection between front panel and back plane PCB

The Displayed output is the single ended voltage (the difference between V+ and Ground) of the Measuring Channel selected. For the meter to display differential output (the difference between V+ and V- Outputs), jumper J7 on the KDM-8206 Measuring Channel must be changed from positions 1 and 2 to positions 2 and 3. (Reference the KDM-8206 System User's Manual)

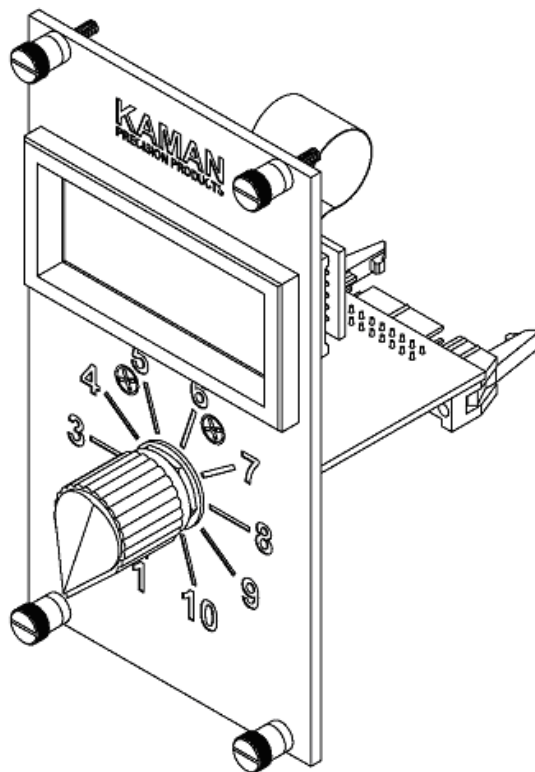

**Figure 5** Display Module Front Panel

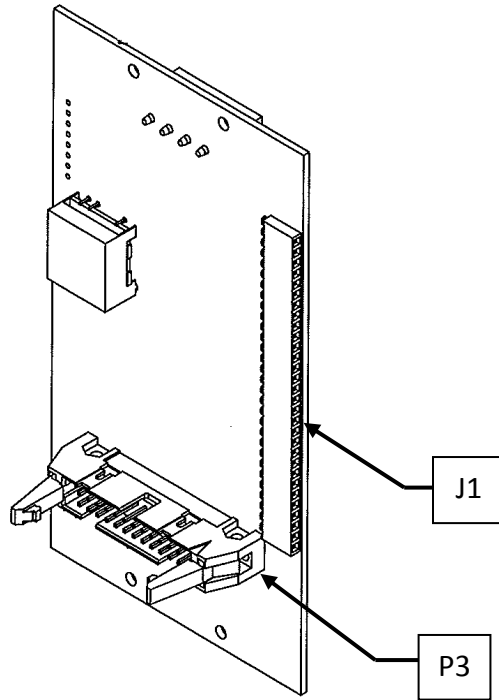

**Figure 6** Display Module Back Plane PCB, Front View

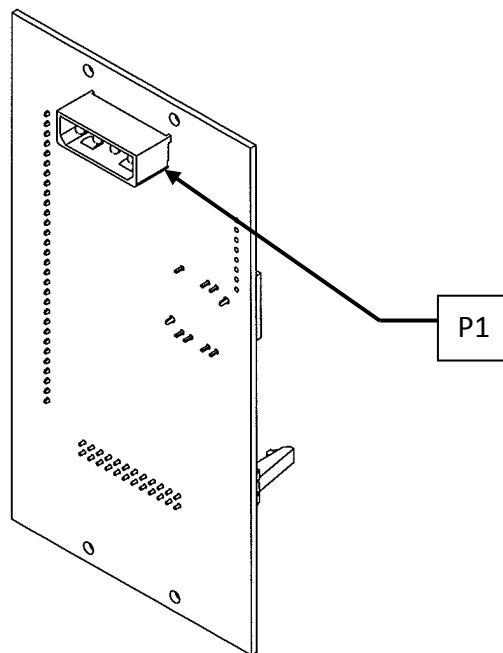

**Figure 7** Display Module Back Plane PCB, Rear View

For Figures 6 and 7 above, the connections labeled are:

- **J1** connects to the back plane PCB of Measuring Channel No. 1
- **P1** input DC power from rack power supply
- **P3** ribbon cable connection to the front panel display module

To configure the rack enclosure for the Display Module, jumpers need to be set on terminal strip P4 on the Back Panel PCB of each Measuring Channel. Placement of jumpers determines the channel on the Display Module where output from that Measuring Channel is displayed.

The top two rows of P4 are for Channel 1 on the Display Module and are labeled V1+ and V1-. When jumpers are placed on P4 connecting pins A and B of that of the V1+ and V1- rows, output is routed to the Channel 1 (switch) position on the Display Module. Rows 3 and 4 (V2+ and V2-) are for Channel 2. Rows 5 and 6 (V3+ and V3-) are for Channel 3. And so on through V10+ and V10- for Channel 10.

Channel 1 is the Measuring Channel adjacent to the Display Module and channels are numbered in sequence from left to right when viewed from the front of the rack or instrument enclosure.

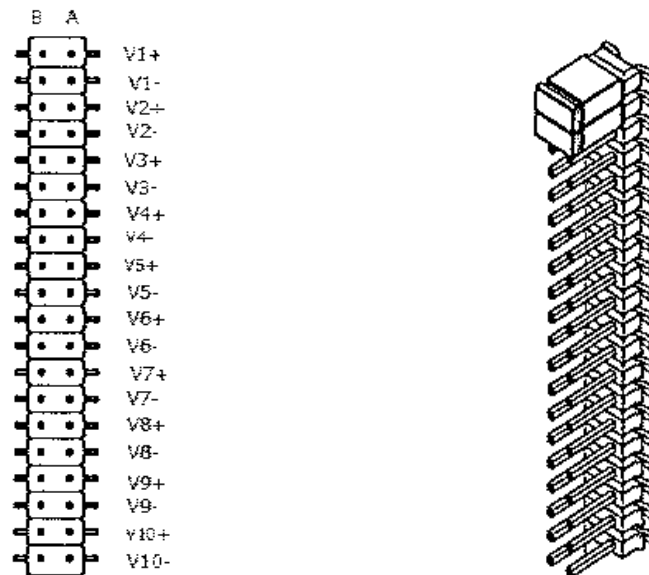

**Figure 8** Back Panel P4 Jumper Configuration

Figure 8 is a depiction of P4. The left side is a top view showing the row labels. The right side of Figure 8 shows P4 with jumpers installed for Measuring Channel 1.

## PART 5 - ENCLOSURES

Kaman Precision Products provides three different enclosures for the KDM-8206 Measuring Channels.

### 5.1 Full 19" Instrumentation Sub-Rack - 3U/84HP

The sub-Rack is a 19" wide frame having solid side panels and horizontal rails across the top and bottom to hold the Measuring Channels in place. Use of a sub-Rack enables installation of the KDM-8206 system into a standard 19" test equipment rack.

The sub-Rack normally includes a built in 120VAC/240VAC power supply to provide  $\pm 15$ VDC required by the Measuring Channels. It also can be configured with a display module that has up to ten selectable inputs.

#### Part Number Configuration

855859-0XX No display module, 12 available positions

855859-1XX One display module, 10 available positions

855859-2XX No display module, rack to rack Synchronization, 12 available positions

855859-3XX One display module, rack to rack Synchronization, 10 available positions

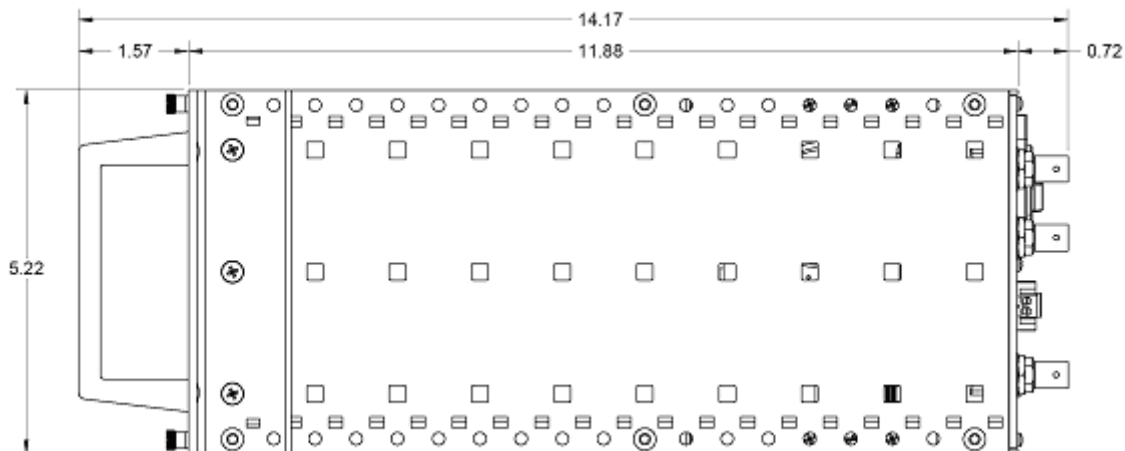

**Figure 9** Full 19" Sub-Rack Side Outline drawing

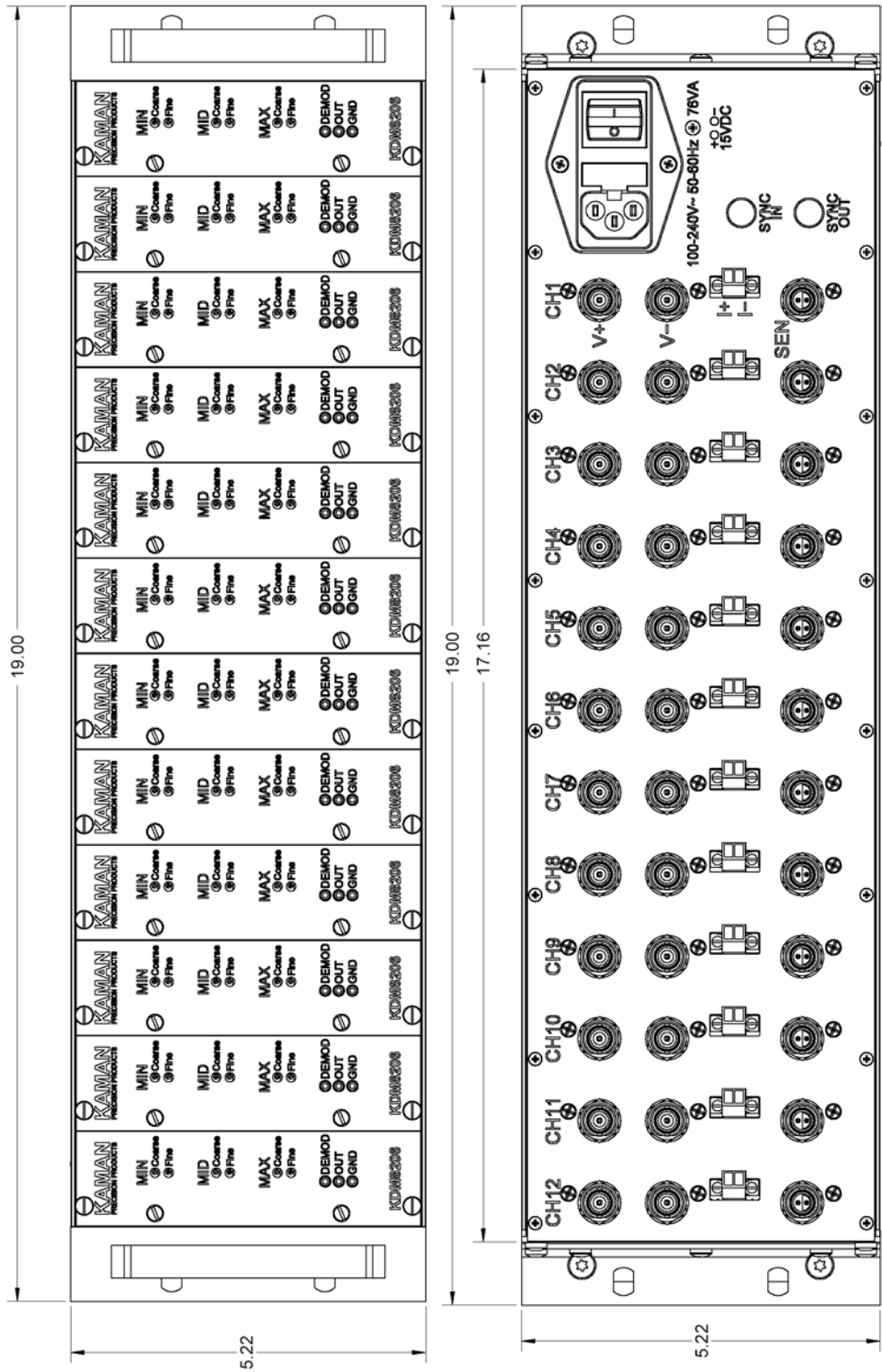

**Figure 10** Full 19" Sub-Rack Rear / Front Outline drawing

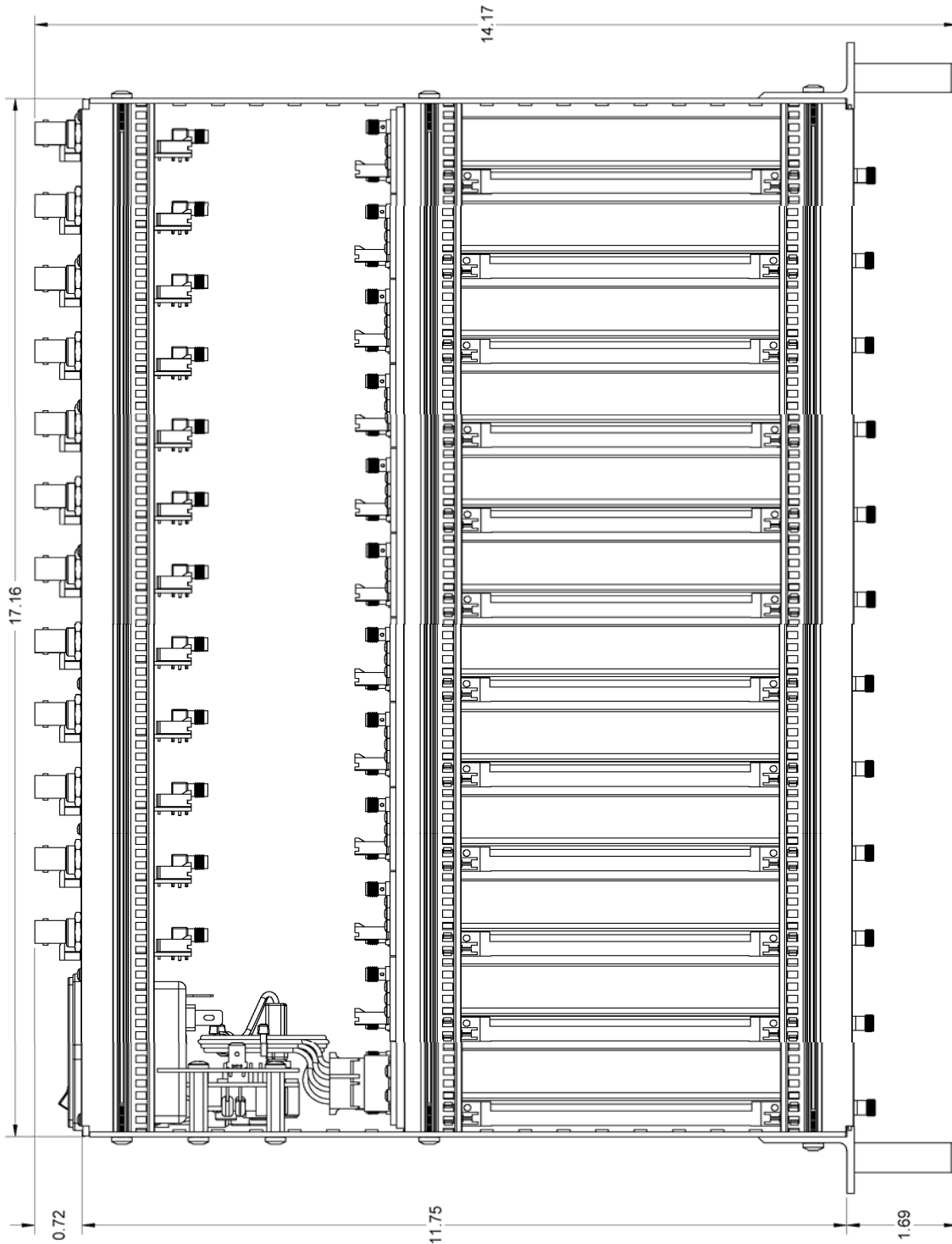

**Figure 11** Full 19" Sub-Rack Top View Outline Drawing



## 5.2 1/2 Rack Instrumentation Enclosure - 3U/42HP

The 1/2 rack instrument case is a fully enclosed stand-alone enclosure for the KDM-8206 system with a tilt bar to elevate the front of the case. The instrument case has an integral 120VAC/240VAC power supply to provide  $\pm 15$ VDC required by the Measuring Channels.

The instrument case also can be configured with a display module with selectable inputs.

### Part Number Configuration

855861-0XX No display module, 6 available positions

855861-1XX One display module, 4 available positions

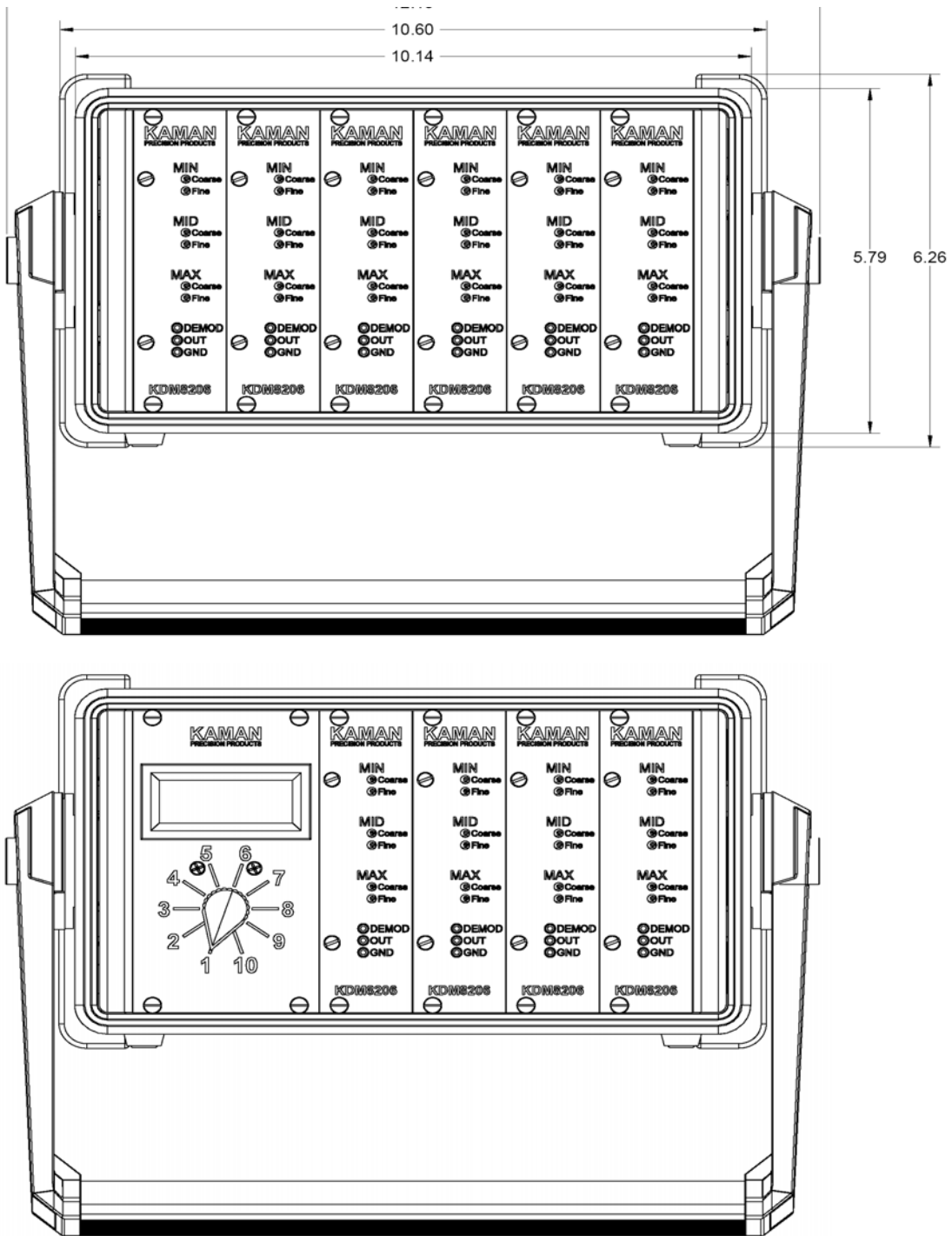

**Figure 13** 1/2 Rack Front View Outline Drawing

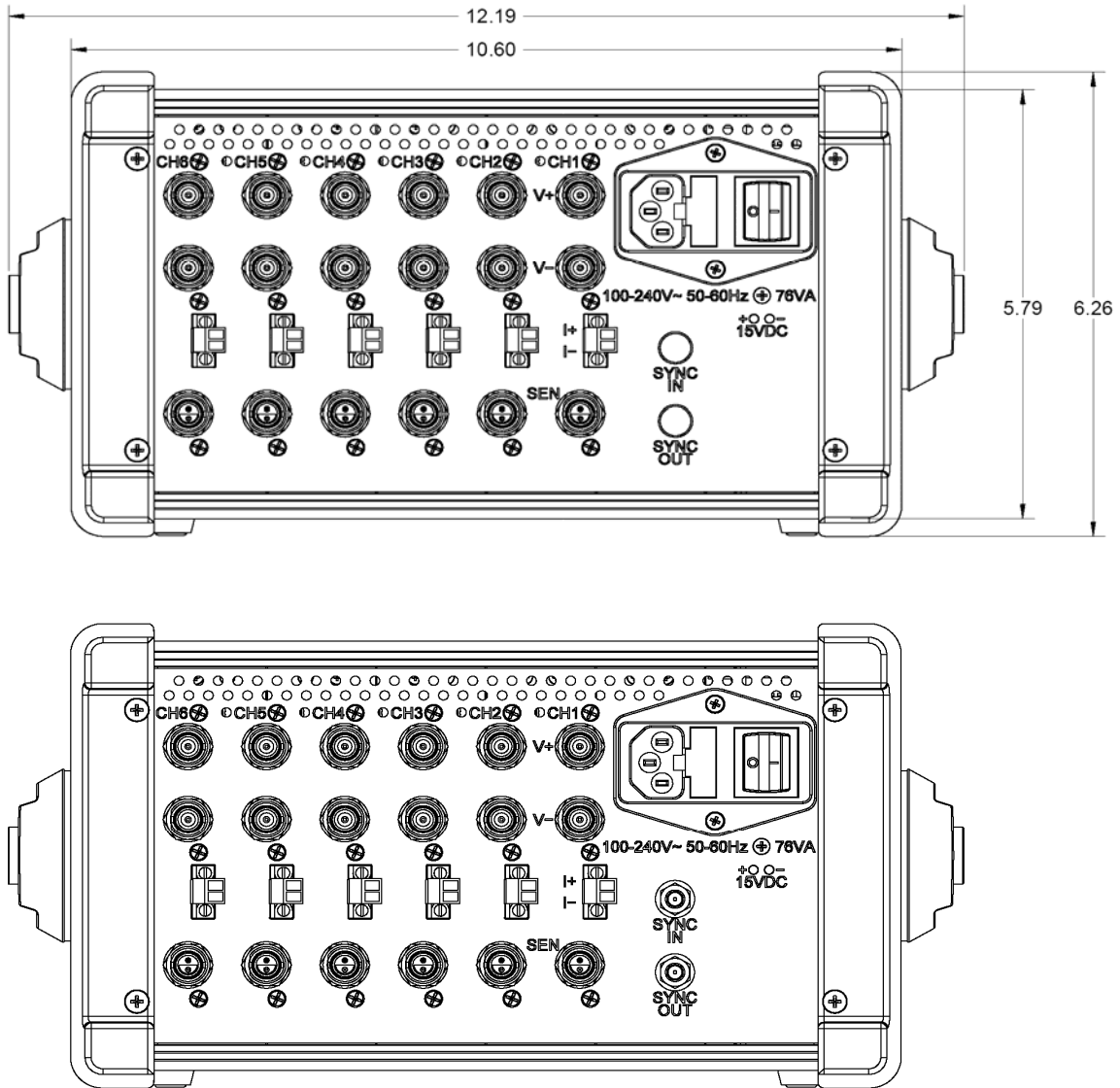

**Figure 14** 1/2 Rack Rear View Outline Drawing

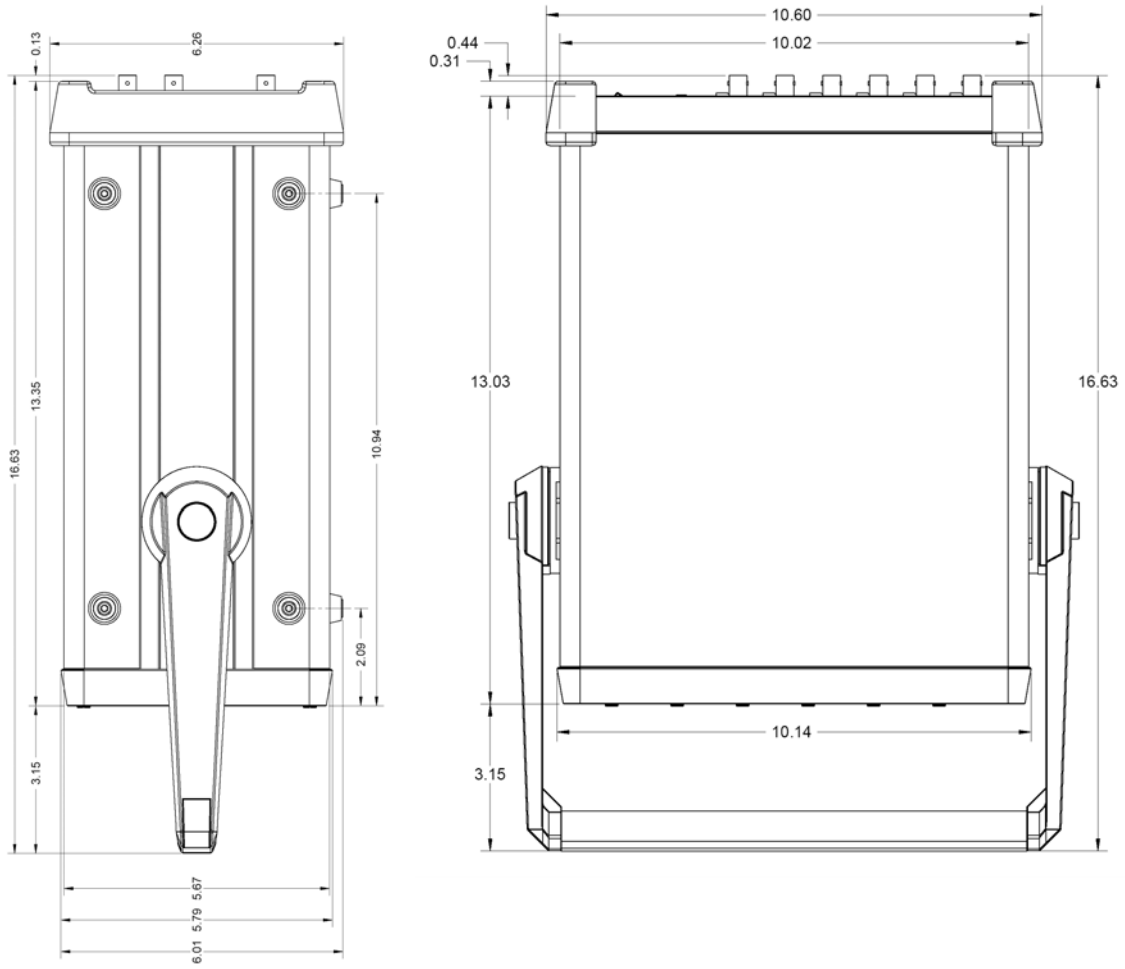

**Figure 15** 1/2 Rack Side/Top View Outline Drawing

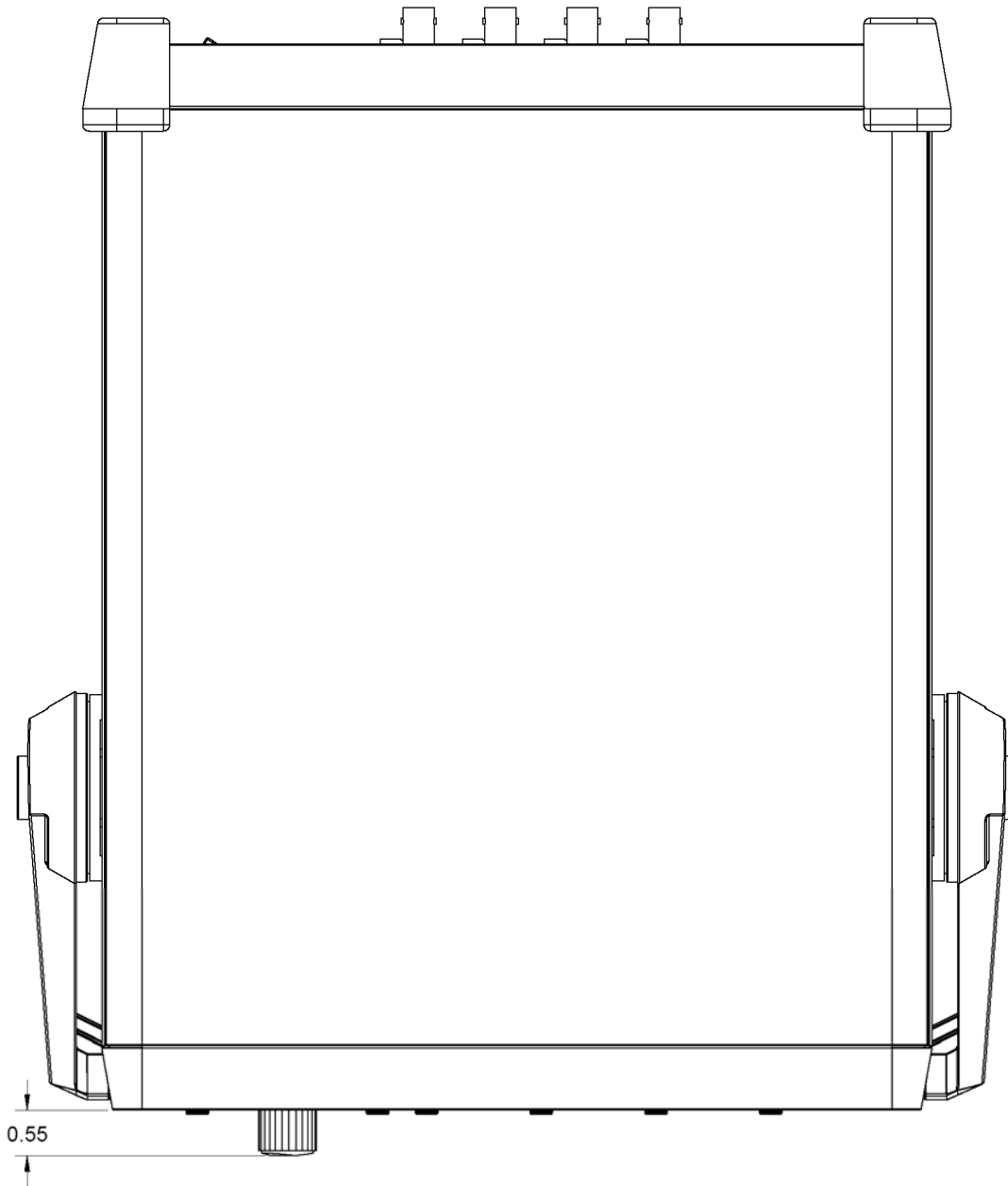

**Figure 16** 1/2 Rack Top View With Display

### 5.3 3/4 Rack Instrumentation Enclosure - 3U/63HP

The 3/4 rack instrument case is a fully enclosed stand-alone enclosure for the KDM-8206 system with a tilt bar to elevate the front of the case. The instrument case has an integral 120VAC/240VAC power supply to provide  $\pm 15$ VDC required by the Measuring Channels.

The instrument case also can be configured with a display module with selectable inputs.

#### Part Number Configuration

855860-0XX No display meter, 9 available positions

855860-1XX One display meter, 7 available positions

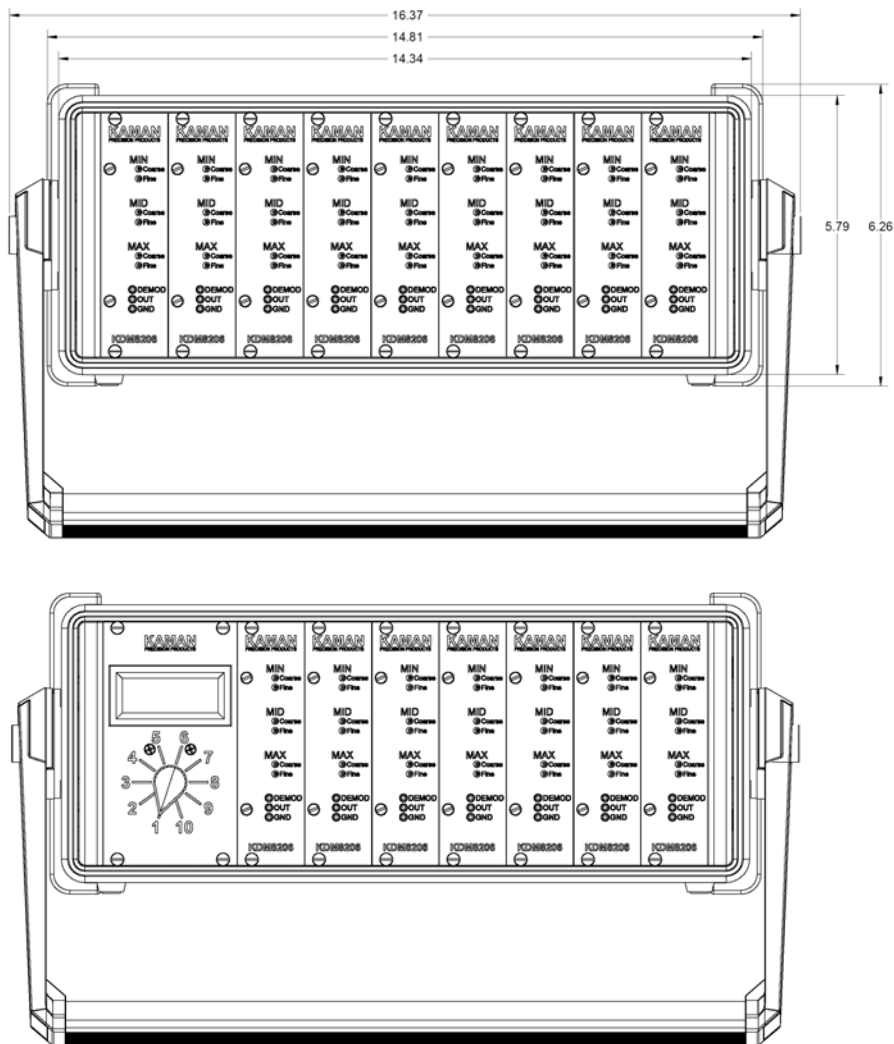

**Figure 17** 3/4 Rack Front View Outline Drawing

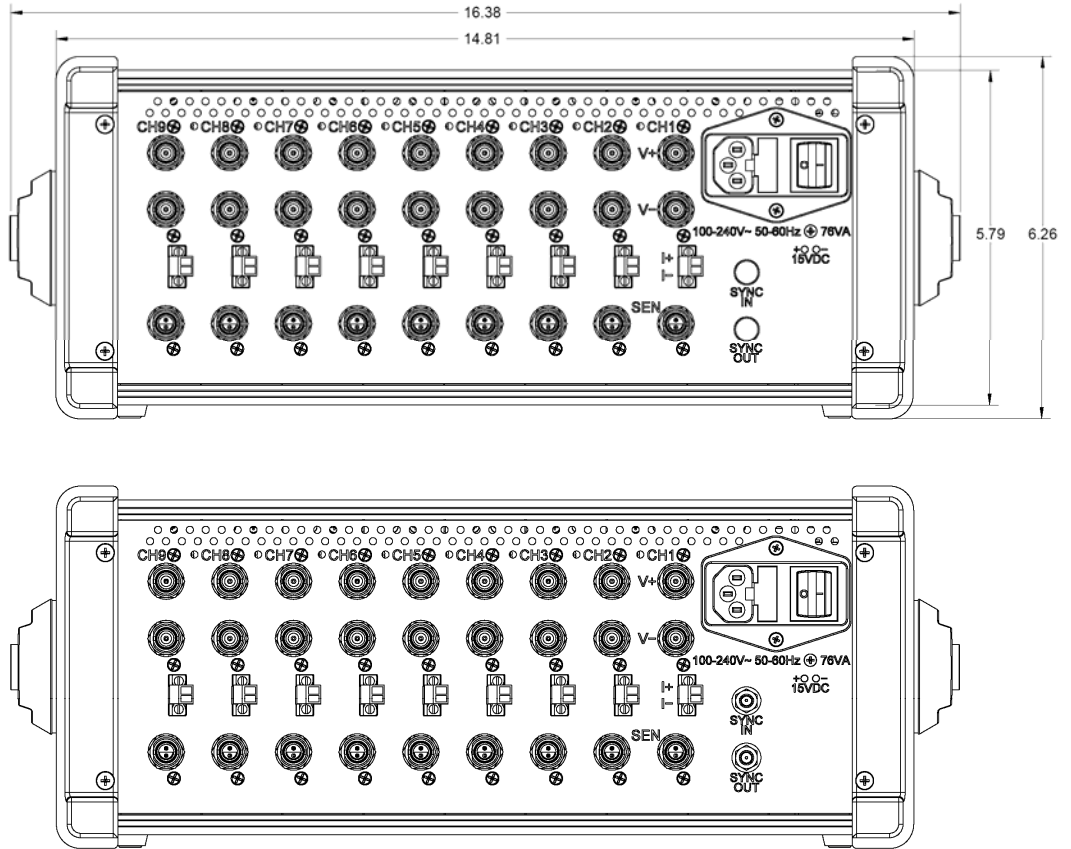

**Figure 18** 3/4 Rack Rear View Outline Drawing

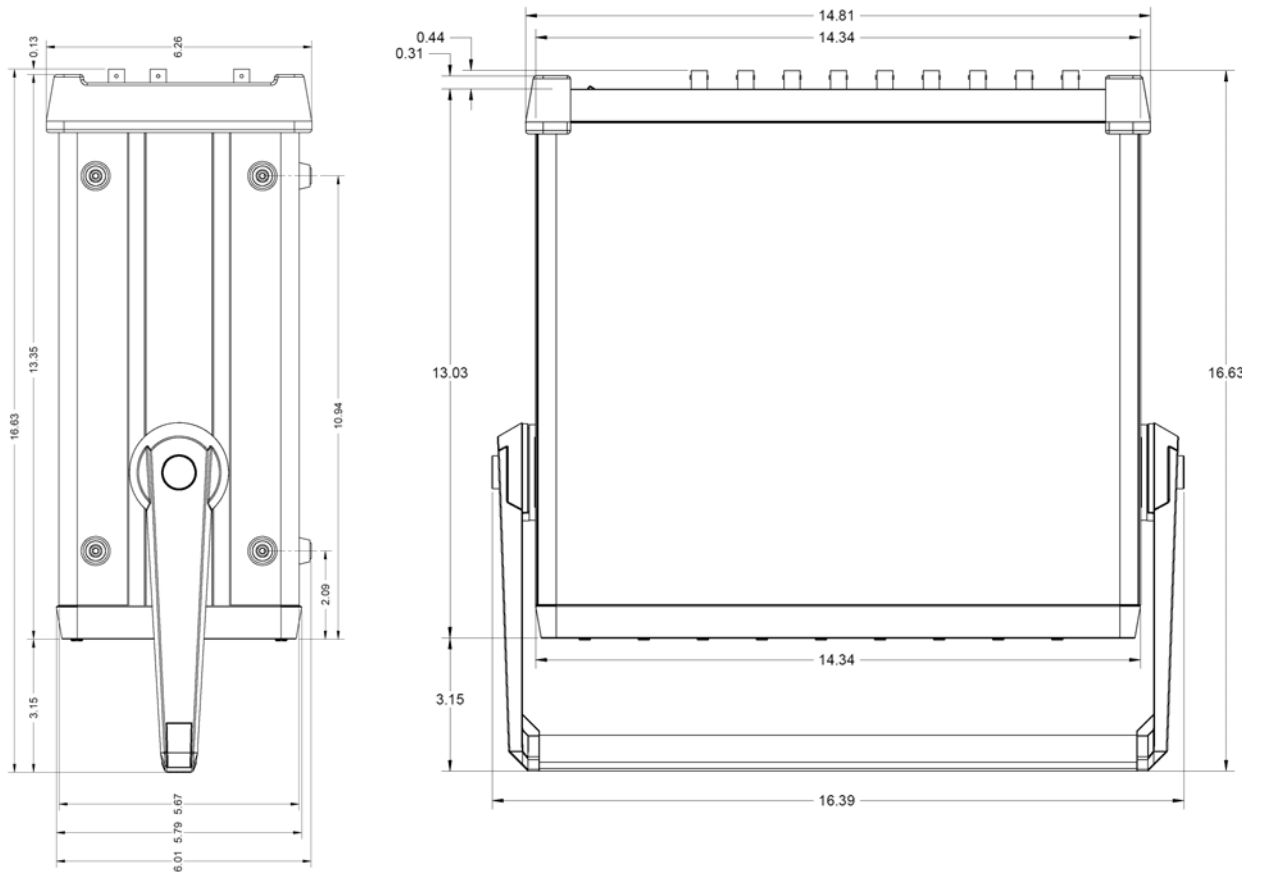

**Figure 19** 3/4 Rack Side/Top View Outline Drawing

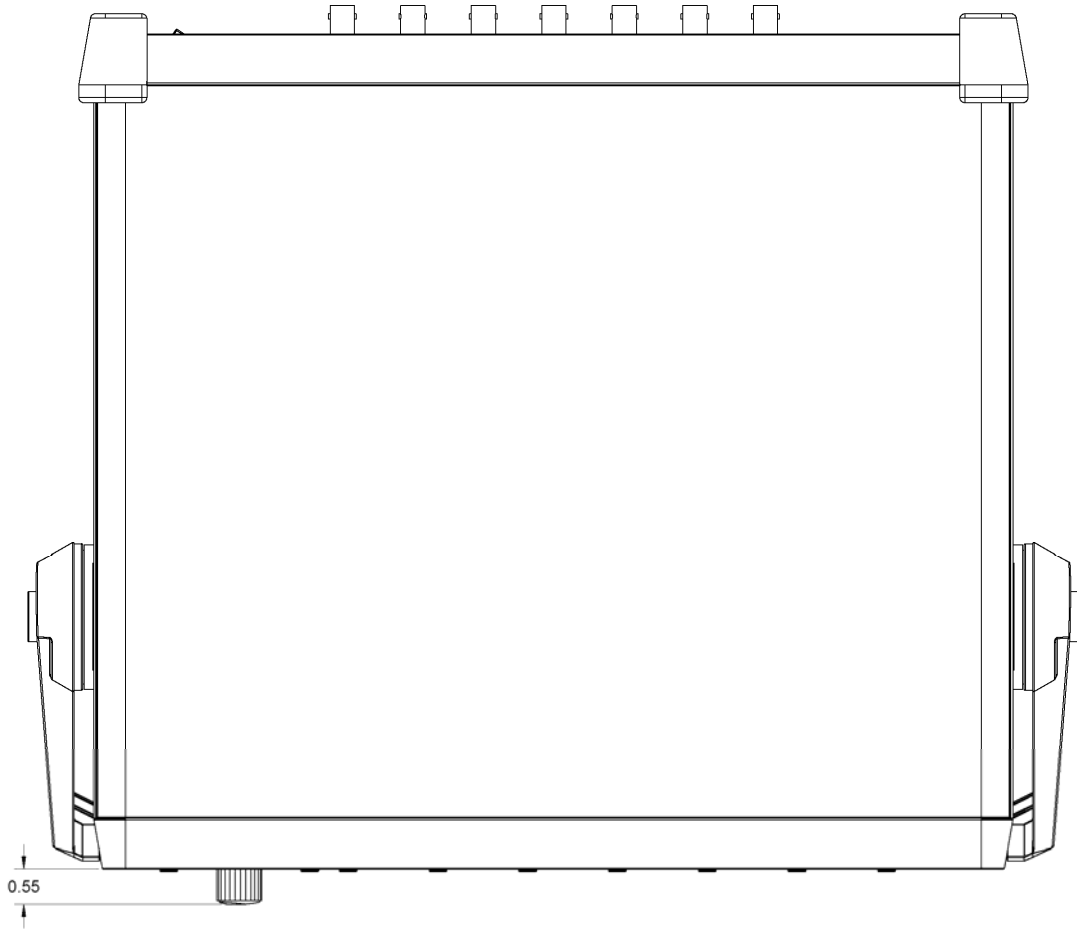

**Figure 20** 3/4 Rack Top View With Display

## PART 6 - INTEGRAL POWER SUPPLY

**WARNING:** The integral power supply utilizes high voltage (100 to 240VAC). Unplug the unit before servicing.

### 6.1 Power Supply

The power supply for the KDM-8206 rack enclosures is integral to the chassis and mounted internally on the side panel. The KDM-8206 power supply provides a  $\pm 15\text{VDC}$  regulated output. The same power supply is utilized for the Full 19" Sub-Rack, the 1/2 Rack Instrument Enclosure, and the 3/4 Rack Instrument Enclosure. It has capacity to power 1 to 12 Measuring Channels, or the Optional Display Module and 1 to 10 Measuring Channels. Power supply specifications are:

Input Power: 100VAC  $\pm 10\%$  to 240VAC  $\pm 10\%$ , 50/60 Hz, 76 VA

Output Power: +15VDC  $\pm 0.5\text{V}$  @ 1A (Peak Load 1.5A)  
-15VDC  $\pm 0.5\text{V}$  @ 0.67A (Peak Load 1A)

No modifications are required to operate the KDM-8206 Sub-Racks or Instrument enclosures for input voltages between 100 and 240VAC.

DC power is distributed from the power supply via a 4 pin connector to the Channel 1 back plane PCB in the first slot. The back plane has a mating connector and can be either a Measuring Channel back plane PCB or a Display Meter back plane PCB. It is then distributed to all channels in the rack via interconnecting back plane PCB connectors for the Measuring Channels.

The power supply is a unique design to provide specific voltages and currents required for the Measuring Channels. It is physically configured to mount on the side rail of the Instrument Enclosures and Sub-Rack.

For Figure 21 below, Power Supply connections labeled are:

- **J1** DC output to Back Plane PCB of Measuring Channel No. 1
- **G1** Input ground from Power Entry Module
- **G2** Chassis ground
- **G3** Chassis ground
- **L** Line AC input from Power Entry Module
- **N** Neutral AC input from Power Entry Module

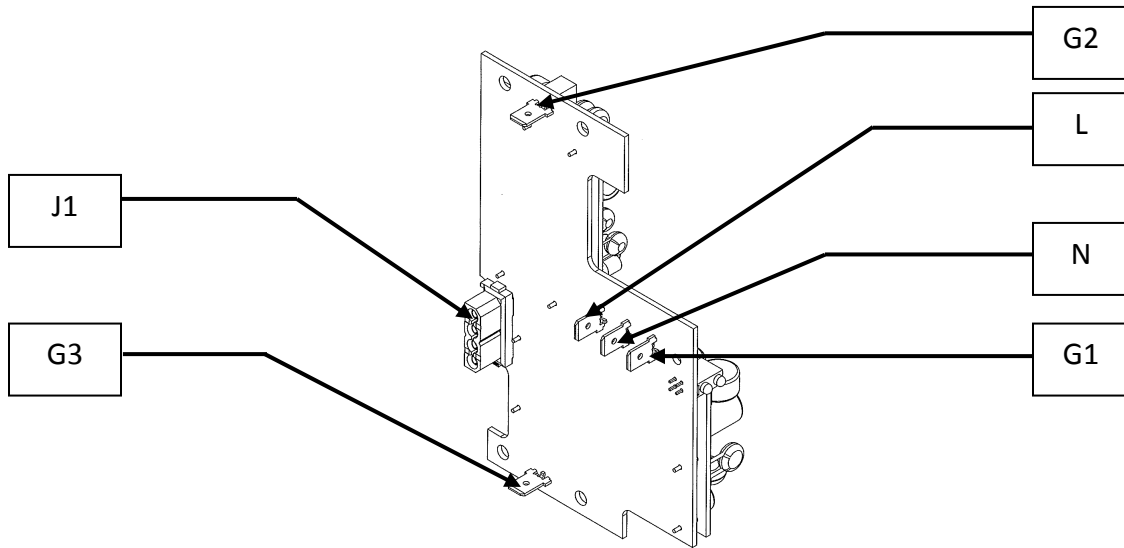
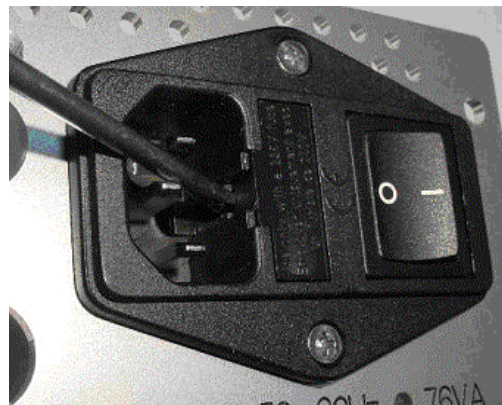
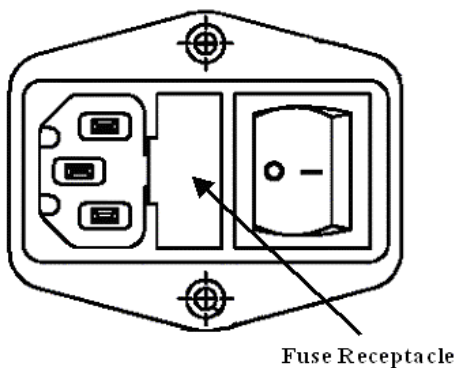

**Figure 21** Power Supply

## 6.2 Power Entry Module

The power entry module provides an on/off switch and a fuse receptacle. If it becomes necessary to replace the fuses refer to Appendix A for the replacement part number.

Use a small flat tip screwdriver or suitable instrument to pry the fuse receptacle out of the power entry module when replacing the fuses.



**Figure 22** Power Entry Module

## APPENDIX A REPLACEMENT OR EXPANSION PARTS

<b>Kaman P/N</b>	<b>Description</b>
827286-022G	FUSE 2.5A 250V T-LAG 5 X 20 MM
816619-100G	ASSEMBLY PANEL BLANK FRONT 7HP
816620-100G	KIT PANEL BLANK REAR
827322-006G	CABLE, RF SMA M/M 6 INCH
827325-G2406G	CABLE, RIBBON 28 AWG 24 COND 6 INCH
855852-001G	BACK PLANE PCB CH 2+
855853-001G	BACK PANEL PCB (W/O DIFFERENTIAL)
855854-100G	KIT MODULAR POWER SUPPLY 8206
855858-000G	KIT MODULAR DISPLAY MODULE 8206